

## Power Steering Fluid Reservoir

### Material

Item	Specification
MERCON® V Automatic Transmission Fluid XT-5-QM (or XT-5-QMC) (US); CXT-5-LM12 (Canada)	MERCON® V

### 4.0L and 4.6L Engine

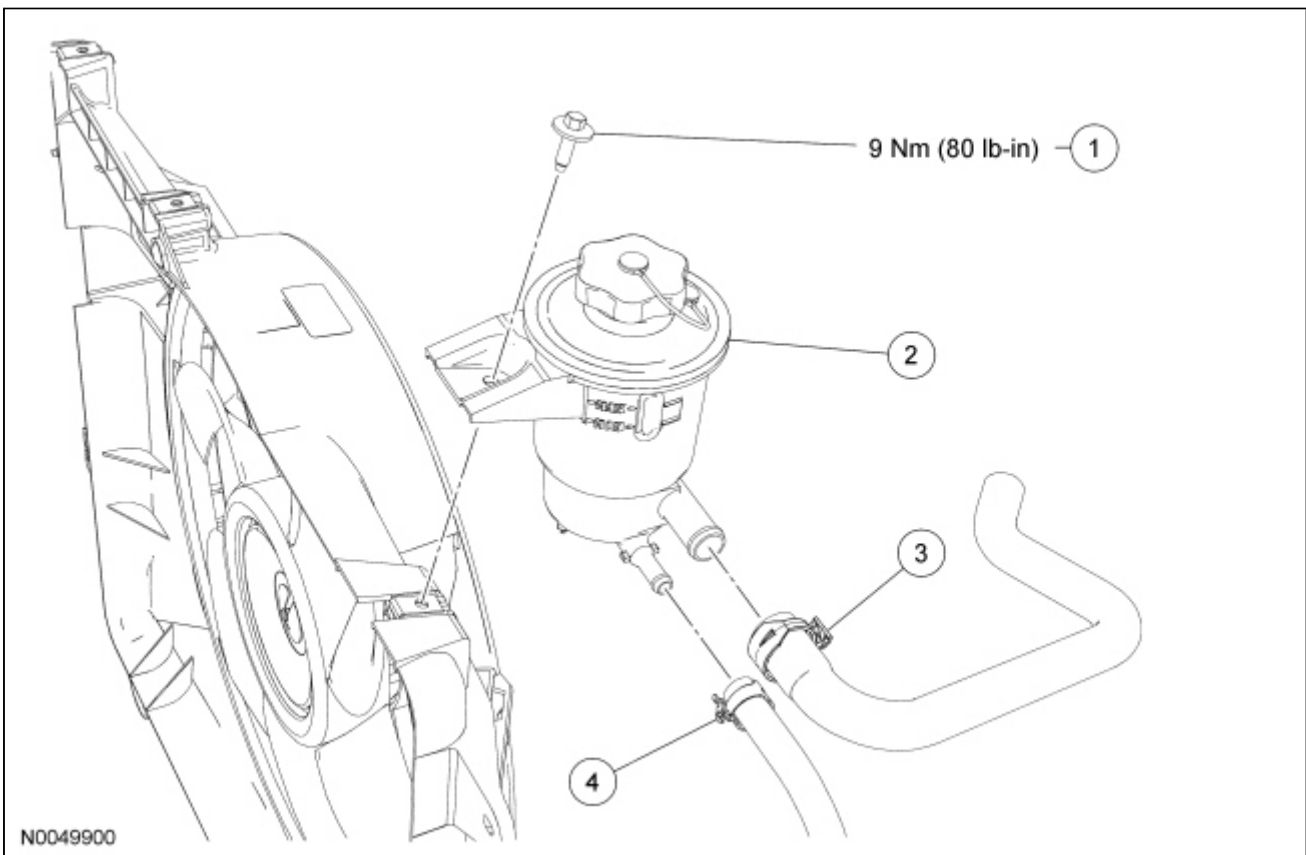

Item	Part Number	Description
1	W503924	Power steering fluid reservoir bolt
2	3A697	Power steering fluid reservoir
3	3691	Power steering pump supply hose
4	—	Power steering fluid return hose (part of 3D746)

### 5.4L Engine

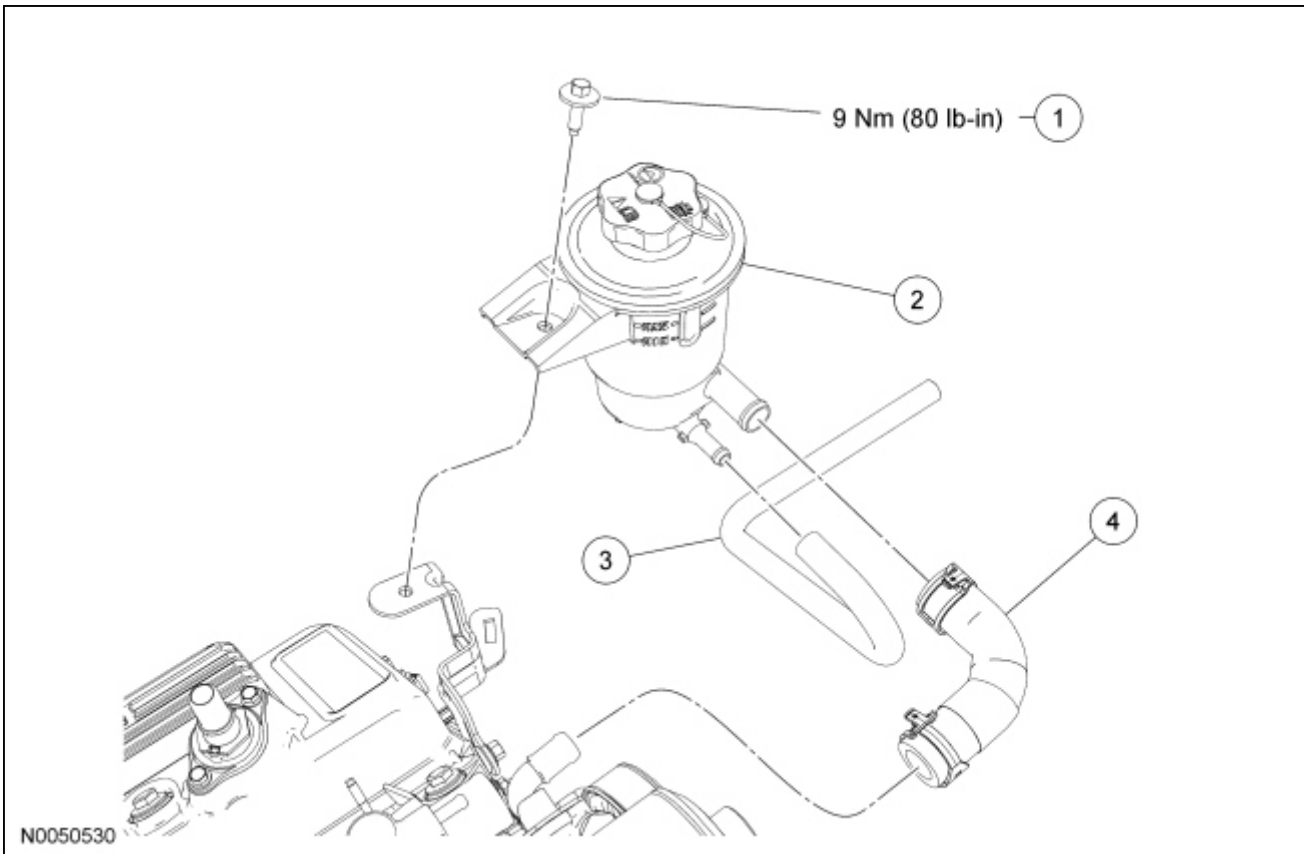

Item	Part Number	Description
1	W503924	Power steering fluid reservoir bolt
2	3A697	Power steering fluid reservoir
3	—	Power steering fluid return hose (part of 3D746)
4	3691	Power steering pump supply hose

### Removal and Installation

**NOTICE:** When repairing the power steering system, care should be taken to prevent the entry of foreign material or failure of the power steering components may result.

1. Using a suitable suction device, remove the power steering fluid from the fluid reservoir.
2. Remove the power steering fluid reservoir bolt.
  - To install, tighten to 9 Nm (80 lb-in).
3. Release the clamp and disconnect the power steering pump supply hose from the power steering fluid reservoir.
4. Release the clamp, disconnect the fluid return hose and remove the power steering fluid reservoir.
5. To install, reverse the removal procedure.
  - Fill the power steering system. For additional information, refer to [Section 211-00](#).

